

5G: An Idea Whose Time Has Come

Youssef El Gholb, Najiba El Imrani El Idrissi, Hicham Ghennioui

Abstract— In order to achieve the goal of “anybody who at anywhere can communicate with anyone at any time by any communication scheme”, broadband radio systems have ambitious objectives in terms of performance and quality of service. Moreover, new network topologies are likely to be introduced. Therefore, the physical layer has to evolve to meet the new requirements. Multicarrier systems are favored for contemporary and future, both stationary and mobile, communication systems. They promise high bandwidth efficiency and at the same time the capability to cope with frequency selective channels. Due to their numerous advantages, communications over multicarrier schemes constitute an appealing approach for broadband wireless systems. Especially, the strong penetration of orthogonal frequency division multiplexing (OFDM) into the communications standards has triggered heavy investigation on multicarrier systems, leading to re-consideration of different approaches as an alternative to OFDM. From sum-capacity and spectral efficiency points of view, orthogonal systems are never the achieving schemes. In this trend, many new multiple access schemes and waveform modulation technologies were proposed. Unfortunately, the peak-to-average power ratio (PAPR) is increased at the transmitter of multicarrier systems compared to single carrier systems. With this in mind, novel multicarrier modulation techniques, which aim at replacing OFDM for next generation wireless communication systems (5G) are discussed in this work. This paper provides a description and a comparison of the most promising techniques for 5G, in sort of a review, enriched by a comparative analysis of their performances in a cellular environment, and by a discussion on their interactions with specific 5G ingredients.

Index Terms— OFDM, CP-OFDM, FBMC, UFMC, GFDM. 4G, 5G, Multicarrier

1 INTRODUCTION

Multicarrier systems provide optimum adaptability to the time and frequency selectivity of propagation channels, which simplifies their equalization. This is very attractive for mobile communication channels, which are subject to multipath propagation and vary frequently with time. They also allow for an adaptation to the frequency response of the channel by using different modulation alphabets and power allocation for the respective subcarriers. In this way, an approximation to the water-filling solution can be achieved and the available bandwidth can be used very efficiently.

The fifth-generation cellular systems (often referred to 5G) will feature several innovative strategies with respect to existing LTE systems, including, among others, extensive adoption of small cells, use of millimeter (mm)-wave communications for short-range links, large-scale antenna arrays installed on macro base stations, cloud-based radio access network, and, possibly, opportunistic exploitation of spectrum holes through a cognitive approach [1]. All of these strategies will be impacted by the modulation format used at the physical layer. At the same time, 5G cellular networks will have more stringent requirements

than LTE in terms of latency, energy efficiency, and data rates, which again are impacted by the adopted modulation scheme.

A well-known multicarrier, thoroughly studied, and heavily applied waveform design principle is OFDM. For instance, both 4G (LTE and its evolutions so far), worldwide interoperability for microwave access (WiMAX), [2] DVB-T and IEEE 802.11 (WiFi) use OFDM as basic signal format for carrying the data. While having many nice aspects, OFDM has a fundamental characteristic making it less attractive for the cellular communication system to come as it carries critical importance due to some shortcomings of such as cyclic prefix (CP) overhead, high side lobes, susceptibility to carrier frequency offset (CFO) and doubly dispersive channels, and larger peak-to-average-power ratio (PAPR) [3]. With the fast-growing number of devices that are to be connected to the Internet, asynchronous access and high level of adjacent channel leakage ratio are among the key requirements of future mobile and wireless communication systems [4][5], future 5G wireless communication systems have to be able to support a very diverse traffic types such as normal broadband traffic, sporadic short packet and urgent low latency transmission [6]. The strict synchronism approach by enforcing synchronicity and orthogonality applied in Long Term Evolution (LTE) is not likely to efficiently fulfill the upcoming challenges arising with the new emerging and imminent communication paradigms such as Massive Machine-type Communications (MTC) [7], move to user-centric processing and M2M that enables ubiquitous and autonomous connectivity between devices and requires minimal or no human intervention [8], [9] i.e., it acts as an enabling technology for the realisation and implementation of Internet-of-Things (IoT) [10] [11]. Furthermore, M2M communications is regarded one potentially disruptive technology that will lead changes in both architectural and component design for 5G networks [12]. In Addition, the authors in [12], [13] argue that 5G networks should have native support for M2M communications.

- Youssef El Gholb is currently pursuing his PhD in Sciences and Engineering Technologie, Faculty of Sciences and Technology, Sidi Mohamed Ben Abdellah University, Morocco.
E-mail : youssef.elgholb@gmail.com
- Najiba El Imrani El Idrissi. She is a full professor and head of Electrical Engineering Department, Faculty of Sciences and Technology, Sidi Mohamed Ben Abdellah University, Morocco.
E-mail : elamrani.naj@gmail.com
- Hicham Ghennioui, he is an associate professor at Faculty of Sciences and Technology, Sidi Mohamed Ben Abdellah University, Morocco.
Email: ghennioui@gmail.com

One major drawback of multicarrier systems is the increase of the PAPR compared to single carrier systems. This increase is the result of the superposition of many statistically independent sub-channels, which can constructively sum up to high peaks [14]. The problem is that practical transmission systems are peak-power limited and show nonlinear characteristics which cause spectral widening of the transmit signal. Clipping is a good example, among several existing PAPR reduction techniques, for the reduction of PAPR but not always because some part of signal clipped that threshold should have to be chosen properly which is generally not chosen properly and Clipping causes in-band noise, which causes a degradation in the BER performance [15]. In [16], the reader can find a comprehensive overview of the used techniques.

Today we are at the start of working towards the next generation—5G, which is likely to be standardized and be rolled out from 2020 in Europe, with the first phase in Korea and Japan by 2018. Currently, a set of research projects are already running, assessing technology candidates and creating consensus building across the wireless industry and the research community. The European METIS research project contains all major players of the industry and has defined a set of requirements for next generation systems. A specialized smaller research project for designing 5G waveforms and a new physical layer is the 5GNOW project, aiming at a relaxation of time-frequency alignment and orthogonality. Future European-funded research projects are currently prepared under the umbrella of 5G PPP, which is a group of companies that have formed the ‘5GPPP Association’ and have worked towards a definition of this research programme [17] [18] in which all companies are proposing their technology solutions to obtain industry recognition, so that they have the right to speak in striving setting 5G standards.

This article provides a review of some of the most credited multiple access schemes and alternatives to OFDM, performs a critical mutual comparison in terms of spectral efficiency, capacity and discusses their possible interactions with the cited technologies and requirements of 5G networks.

2 WAVEFORMS DISCRITION

2.1 OFDM

OFDM is a multicarrier transmission technique where a high-rate serial data is transmitted in parallel at a slower rate via multiple narrowband orthogonal subcarriers. It is a very popular special case of a multicarrier system, used in many current standards because of its efficient implementation with Fast Fourier Transforms (IFFT and FFT), Fig1, and its “simple” equalization. This equalization is realized by a time-domain guard interval and a simple complex scaling for each subcarrier. The question is, what should we put within GI that we could decode correctly our symbol? As an answer, we should restore the carriers' orthogonality which was lost. To do that we copy the end of our symbol and paste it on the beginning, this called ‘cyclic prefix’ (CP) Fig2. This holds true as long as the CP exceeds the effective channel impulse response, which incorporates the pulse shaping filters at the transmitter and the receiver and the propagation channel. Its cyclic prefix (CP) allows transforming the linear convolution of the channel into a cyclic convolution, thus deals very elegantly with multi-path propagation, at the

price of additional overhead of the CP. But the bandwidth efficiency is reduced up to 25 %. For instance, regarding the spectral efficiency loss of side lobes and the CP, in an LTE system operating at 10 MHz bandwidth, only 9 MHz of the band is used. Also, the loss of the CP is around 7%, so the accumulated loss totals at 16%. In addition to such as cyclic prefix (CP) overhead, high side lobes, susceptibility to carrier frequency offset (CFO) and doubly dispersive channels, and larger peak-to-average-power ratio (PAPR) [6] and the impossibility of having strict frequency synchronization among subcarriers, are some of critical shortcomings of OFDM. These drawbacks invalidate many of the OFDM/ OFDMA’s advantages; form the basis of an open and intense debate on what the modulation format and multiple access strategy should be in next-generation cellular networks. In particular, synchronization is a key issue in the up-link of a cellular network wherein different mobile terminals transmit separately [19], and, also, in the downlink when base station coordination is used [20], [21].

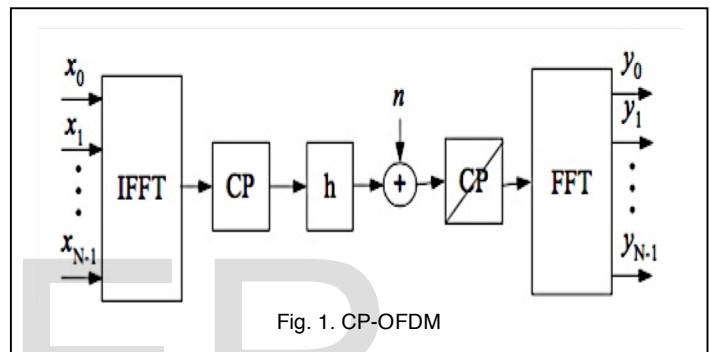

Fig. 1. CP-OFDM

However, the CP-OFDM is perfect only if the transmission condition is perfect, e.g. perfect synchronization and pedestrian speed; This is because CP-OFDM does not have localized signal spectrum confinement, which is further due to two facts: I) the spectral leakage due to the waveform discontinuity, which happens at the edges of each CP-OFDM symbol; II) the IFFT window indeed leads to a sinc-pulse character in the frequency domain with a very slow side lobe attenuation, e.g. the second lobe attenuation is 13 dB. LTE can achieve those conditions by applying a closed loop ranging mechanism and demanding very strict oscillator requirements. The time domain samples of an OFDM symbol can be calculated using an N point IFFT as

$$x_n = \sum_{k=0}^{N-1} X_k e^{j2\pi nk/N}, \quad n = 0, 1, \dots, N-1$$

Where X_k is the complex modulation value for the sub-carrier with index k . Then, prior to transmission, a Cyclic Prefix (CP) is added to each symbol. Although the channel equalization can be performed in a simple manner exploiting the CP, this method reduces the effective data rate of the system.

To sum up, for the CP-OFDM scheme, the low transceiver complexity, simple equalization in frequency domain, less complex implementations through fast Fourier transformation (FFT), efficient usage of spectrum through frequency overlapping while limiting time signal over a perfect rectangular block, and MIMO-friendly are the main advantages. While it has some well known drawbacks:

- To perform interference free demodulation, the subcarriers have to remain orthogonal, otherwise system performance will degrade. Therefore, OFDM is very sensitive to frequency offset originating from the mismatch of transmitter and receiver local oscillators.
- The time domain OFDM signal is a sum of a large number of complex sinusoids, which means that, according to the central limit theorem, the amplitude distribution will be Gaussian, leading to a large PAPR of the signal. Hence, a power amplifier with a relatively large linear range is required, otherwise non-linear effects will severely degrade the system performance, which one major problems in satellite communications where the power amplifier has to operate close to saturation region or applied a back off to bring it to linear region. But there are methods like DFT-precoding used in conjunction with CP-OFDM to build up single-carrier FDMA for bringing down PAPR, Fig3.
- The frequency domain sinc-pulse feature, which results in a slow side lobe decay, is the potential improvement to be addressed. Although suggestions have been made to improve the side lobes of OFDM analysis and synthesis filters through the the use of filtered OFDM.

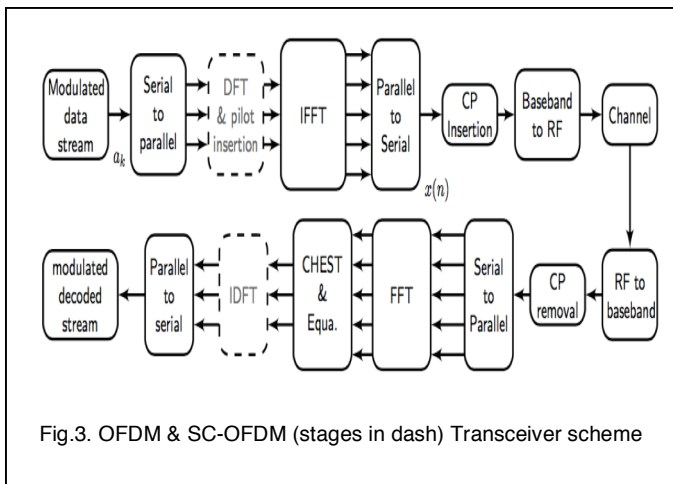
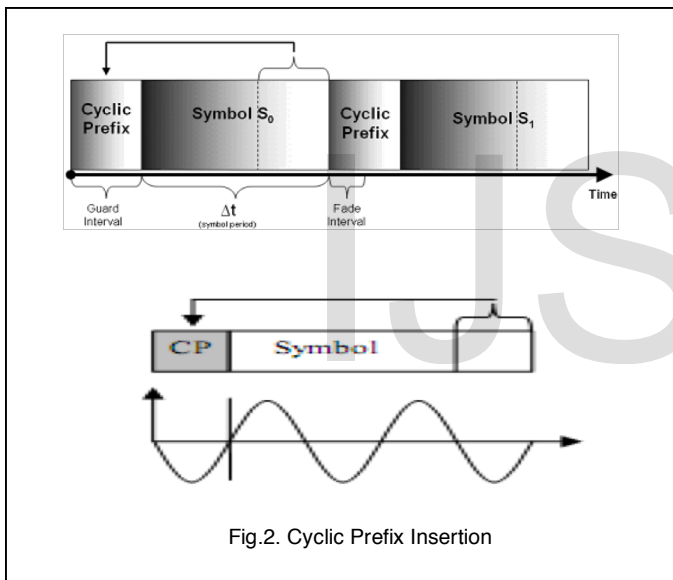

2.2 GFDM

Generalized Frequency Division Multiplexing (GFDM) [22] is a multi-carrier system, which digitally implements the classical filter band approach. It is a non-orthogonal multicarrier scheme that provides flexible pulse shaping. This is attractive for various applications like machine-to-machine communications or cognitive radio. However, this degree of freedom and additional flexibility is obtained at the cost of loss of subcarrier orthogonality, which is traded for self-created interference that degrades BER performance. In OFDM, ICI cancellation is a well-researched area. [23], [24] proposed innovative ICI self-cancellation techniques for OFDM systems in presence of frequency offsets or time variations in the channel. But the issue of ICI in GFDM is different, as the ICI is self-generated by the system itself due to the inherent non-orthogonality of the subcarriers because of pulse shaping, Fig5. The authors in [22] were able to demonstrate that the self-introduced ICI caused by the RRC pulse can be mitigated successfully, for more insight we strongly ask the reader to refer to the reference herein. Cyclic prefix (CP) insertion is used to allow for low complex equalization at the receiver side. It is similar to FBMC (see the coming section) with subcarrier-wise pulse shaping. It adopts a shortened CP through the tail biting technique and is particularly well suited for non-contiguous frequency bands, which makes it attractive for spectrum sharing where frequency-domain holes may have to be adaptively filled. In Fig.4, a tail biting technique (circular convolution with the filters instead of linear convolution) is used to be attractive for short bursts and to shorten the cyclic prefix [25] in order to enhance the spectral efficiency. Every subcarrier is modulated individually, using some form of QAM signalling.

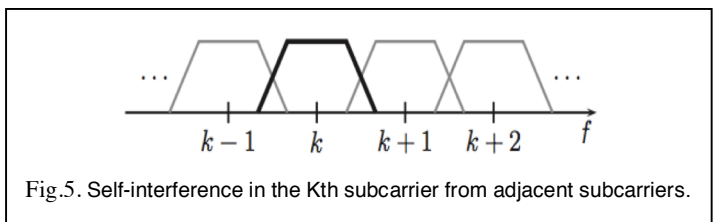
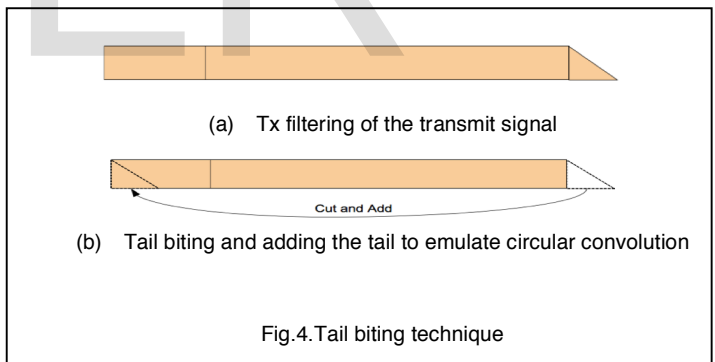

Let's denote the QAM symbol stream on subcarrier n as

$$d(n,k)$$

Where k represents the QAM symbol index. After up-sampling, the symbols index now turns into the sample index k' , representing the sample duration T_s . Subsequently, cyclic prefix

insertion is performed, accounting for the filter length of the digital pulse shaping, the filter length of the digital receive filter and the length of the mobile channel impulse response. After cyclic prefix insertion, digital pulse shaping is performed sub-carrier-wise, which yield low out of band radiation. Sharp filter edges are required which in turn necessitate high Tx-filter orders. Large filter orders are generally problematic due to the cyclic prefix, which has to be matched to the aggregate filter lengths of all system filters involved. However, a CP reduction for the Rx filter can be done as well, if pre-coding techniques are applied, which increase transmit power. It can be mitigated, for instance, when using non-linear pre-coding techniques and modulo constellations, the reader can refer to [26]. After individual subcarrier pulse shaping, each carrier n is digitally shifted to its carrier frequency f_n , which is normalized to the signal bandwidth $B = 1/T_s$. The resulting time domain signal $x(k')$ hence becomes

$$x(k') = \sum_1^n (d(n, k') * g_{Tx}(n, k')) e^{j2\pi k' f_n}$$

Finally, $x(k')$ is digital-to-analogue converted, mixed to the carrier frequency, amplified and transmitted. After passing the LNA and the down conversion stage, the received signal is analogue-to-digital converted from which we obtain the digitized received signal $r(k')$. Here, $r(k')$ is given by the discrete convolution of the Tx-signal $x(k')$ with the channel impulse response $h(k')$, corrupted by zero-mean additive white Gaussian noise $n(k')$ with variance σ_n^2 :

$$r(k') = x(k') * h(k') + n(k')$$

So the SNR can be defined as follows:

$$snr = \frac{E\{|(x(k') * h(k'))|^2\}}{\sigma_n^2}$$

The received signal is then mixed to baseband individually in each of the digital receiver branches and filtered subsequently, Rx-filtering is used to cancel out the undesired adjacent channel interference, yielding the signal $y(n, k')$

$$y(n, k') = (r(k') e^{-j2\pi k' f_n}) * g_{Rx}(n, k')$$

However, steep filter edges, would provide low inter channel interference (ICI) and therefore higher SNR. But, sharp filter edges typically require high filter orders, which in turn have to be compensated by an appropriate cyclic prefix length, decreasing the system spectral efficiency. After digital Rx-filtering, the signal is down-sampled turning the sample index k' back into the QAM symbol index k . The cyclic prefix is removed and the signal $y(n, k')$ is transformed using FFT in order to yield the frequency bins $Y(n, l)$ of the n -th subcarrier signal. The signal model can now be written as:

$$Y(n, l) = D(n, l)H(n, l) + W(n, l)$$

Where $H(n, l)$ denotes the FFT transformed effective channel, consisting of the Tx-filter, the Rx-filter and the channel.

To sum up, GFDM boasts some attractive features such as providing an effective alternative for spectrum white spaces aggregation in the TV UHF (ultra-high frequency) bands which are located in close proximity to allocated spectrum, a ultra-low out-of-band radiation due to adjustable Tx-filtering and efficient FFT-based equalization, which is achieved when using a cyclic prefix in conventional single carrier systems, leading to the SC-CP (single carrier with cyclic prefix) system concept as applied in LTE uplinks and a lower PAPR leading to a reduced hardware cost and power consumption, which is in turn an important point of sale for future wireless communication systems. Due to its better spectral shaping and sensing characteristics GFDM is also a good candidate for cognitive radio PHY [27]. From the above signal generation scheme we can interpret GFDM as parallel SC-CP system realized in the digital domain. In a more general scheme, GFDM transceiver can be schematized as in the Fig5, based on time-frequency filtering of data blocks of size $(K * M)$, CP added at each symbol (P symbols in this case). On the receiver side, different equalizations schemes can be adopted. MMSE, MF with the need to add Interference Cancellation (IC) scheme and ZF with no self-interference but noise enhancement.

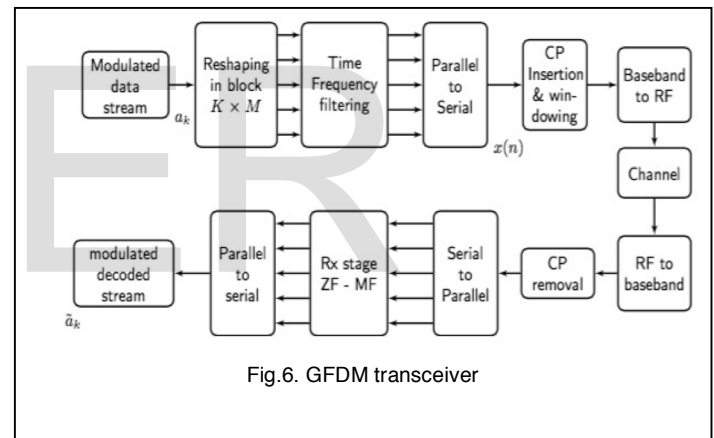

Fig.6. GFDM transceiver

The details of the GFDM modulator are shown in Fig.7. Each $d_{k,m}$ is transmitted with the corresponding pulse shape modulo operation makes $g_{k,m}[n]$ a circularly shifted version of $g_{k,0}[n]$ and the complex exponential performs the shifting operation in frequency.

$$g_{k,n}(n) = g[(n - mK) \bmod N] e^{-2\pi \frac{k}{K} n}$$

with n denoting the sampling index. Each $g_{k,m}[n]$ is a time and frequency shifted version of a prototype filter $g[n]$, where the modulo operation makes $g_{k,m}[n]$ a circularly shifted version of $g_{k,0}[n]$ and the complex exponential performs the shifting operation in frequency[28].

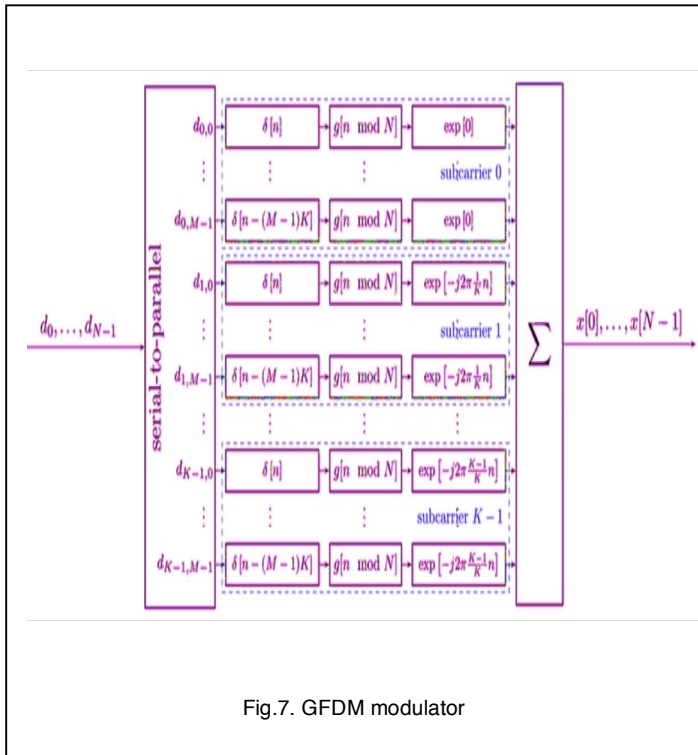

Fig.7. GFDM modulator

2.3 FBMC

FBMC has been promoted in recent years as a potential contender. A filter bank based multicarrier transmission system employs two filter banks, a synthesis filter bank (SFB) at the transmitter side and an analysis filter bank (AFB) at the receiver side. In such a system, there is no need for guard times to separate consecutive symbols, as in the Digital MultiTone (DMT) technique implemented in Asynchronous Digital Subscriber Loop (ADSL) equipment's for example. The consequence is an increase in efficiency and, also, a significantly enhanced robustness. Since the sub-channels are well separated, high level narrow-band disturbing signals or jammers affect only a few sub-channels, efficient sub-channel equalizers can be used, constraints on synchronization are relaxed and the initialization sequence at the beginning of a connection can be shortened. Considered one of the Broadband Wireless Access (BWA) options that may address the shortcomings of OFDM while maintaining some of its advantages. Prototype filter controls the phase and amplitude distortions in the sub-channels and the interference between sub-channels. Phase distortion is eliminated if the prototype filter is linear phase. Though FBMC is better suited than OFDM in theory, practical considerations pinpoint many issues of FBMC. In principle, the square of the frequency response must satisfy the Nyquist criterion for data transmission and amplitude distortion produces intersymbol interference in the receiver. However, if a sub-channel equalizer is employed, some flexibility can be introduced. FBMC has some advantageous characteristics rendering it a promising contender. Instead of digitally filtering the complete band as the case in OFDM, the modulator includes a filtering functionality on a per subcarrier basis. So, instead of sinc-pulses the subcarriers have a more suitable shape according to the filter design with reduced side lobe levels. A straightforward and efficient design

method, which has been shown to be well suited for multicarrier communications and is currently being considered in the context of cognitive radio [29], is the frequency sampling technique [30] in which a near perfect reconstruction prototype filters can be expressed using a closed-form representation with only a few adjustable parameters. With this design, ideally, a single unused sub-channel is sufficient for creating a necessary guard band between asynchronous adjacent multiplexes. Earlier works related to FBMC date back to 1960s [31][32], which utilize a bank of filters for parallel data transmission. As an alternative, filter bank based multicarrier (FBMC) technique is combined with OQAM (offset quadrature amplitude modulation) [32, 33,34], which has recently drawn increasing attention as it shows strong potential to overcome the limitations of OFDM at a cost of somewhat increased processing complexity. The subcarrier filters are very narrow in frequency and thus require rather long filter lengths (typically up to 4 times the basic multicarrier symbol length, indicated by the overlapping factor K (a key design parameter of FBMC) and thus the single symbols are overlapping in time accordingly. FBMC requires orthogonality for the neighbouring sub-channels only. In fact, OFDM exploits a given frequency bandwidth with a number of carriers, while FBMC divides the transmission channel associated with this given bandwidth into a number of sub-channels. To fully exploit the channel bandwidth, the modulation in the sub-channels must adapt to the neighbour orthogonality constraint and Offset Quadrature Amplitude Modulation (OQAM) is used to that purpose, which is a serious problem for scalability and requires doubling the processing rate in the transceivers [35]. So, FBMC is not orthogonal with respect to the complex plane. Due to OQAM it is e.g. not compatible to all kinds of multiple input multiple output (MIMO) antenna techniques in a straightforward manner, which a critical issue as MIMO is regarded as one of the key technologies for 5G. Furthermore, the long filter lengths make short burst transmissions inefficient, due to filter ramp up and ramp down time. With the emergence of the IoT, use cases will be present requiring the transport of very small packets and/or the guarantee of very low latencies. Both require very short burst lengths rendering the overhead of multiple symbol lengths very painful. However, the so-called burst truncation [36] was proposed, to remediate the issue, which applies a windowing functionality shortening filter ramps. Consequently, the out-of-band radiation and inter-carrier interference increase is the price to pay. Another option to overcome this issue is to significantly increase the width of the subcarriers decreasing the length of the single multi-carrier symbols and increasing the number of symbols carrying the data accordingly. Unfortunately, the channel responses may not be flat anymore within the range of a single subcarrier, making channel equalization much more complex, so again a cost to be paid. Although this gives the opportunity to perform fractionally spaced time domain equalization in the receivers at sub-channel outputs, it remains a drawback in terms of processing organization and computational complexity. Moreover, the authors in [7] has showed that channel equalization in FBMC systems, as well as carrier frequency offset compensation, can be achieved in the frequency domain with improved performance and no additional delay. Another critical issue is that OQAM is unable to efficiently support some basic MIMO techniques that are introduced in the new wireless standards. OQAM in the current FBMC approaches comes from the overlapping of neighbouring sub-channels. The interference filter response to a real impulse is zero in the middle of the symbol period for the imaginary part, which allows cancellation of the interference by

alternating real and imaginary data samples. But, there is another way to cancel interference; it consists of introducing phase shifts that are multiples of $\pi/2$ in the sub-channels. The technique is known as pseudo-quadrature mirror filters (QMF) and it has been used for decades in multimedia signal analysis and compression, for more insight the reader can refer to [37]. The fact, that CP overhead is avoided FBMC scheme makes it, suffer from an intrinsic ICI and ISI, which makes the channel estimation procedure more complicate. Regarding the very basic principles two variants of FBMC exist filtered multi-tone (FMT) and staggered multi-tone (SMT) [38]. SMT exhibits higher spectral efficiency and is more heavily promoted than FMT [39,40]. To achieve a time-frequency efficiency of 1 SMT needs to stagger the multi-carrier symbols in time and has to apply offset-QAM (OQAM) as already mentioned. So, in case of complex symbols to be transported (QPSK, xQAM) the transmitter splits the symbols into real and imaginary part and modulates them on consecutive symbols. By doing so a chessboard like structure is achieved with real and imaginary symbols alternating both in time and frequency direction. Different to systems applying OFDM, SMT is not orthogonal with respect to the complex plain. Each subcarrier introduces interference to the subcarriers in its neighborhood (the area of influence depends on the parameters of the modulator e.g. the overlapping factor). Thanks to the use of offset-QAM the interference is easily cancelled at the receiver by ignoring the part of the received symbol not carrying the data.

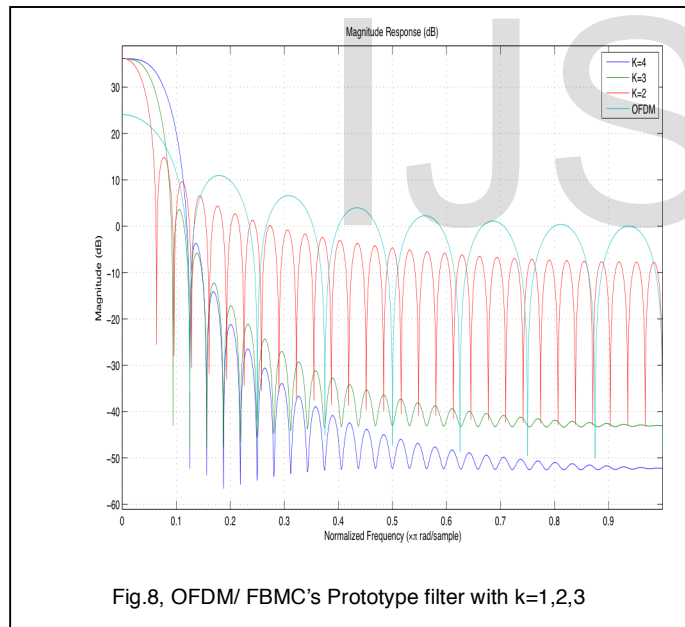

Fig.8, OFDM/ FBMC's Prototype filter with k=1,2,3

As mentioned before, FBMC applies a filtering functionality on a per subcarrier basis. So, the frequency response of the filter needs to be rather tight, requiring very long filter lengths (relative to the length of a single symbol). Typically filter lengths, of three or four times the symbol length, are used. So, long ramp up and ramp down areas are required in case of bursty data transmission. Both the fact that subcarriers are spilling interference into its neighbor subcarriers and the need for very long filters causes various issues especially if practical system aspects are applied.

The combination of filter banks with OQAM modulation leads

to the maximum bit rate, without the need for a guard time or cyclic prefix as in OFDM.

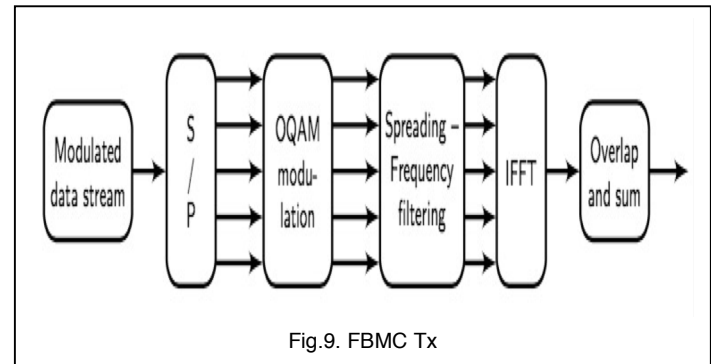

Fig.9. FBMC Tx

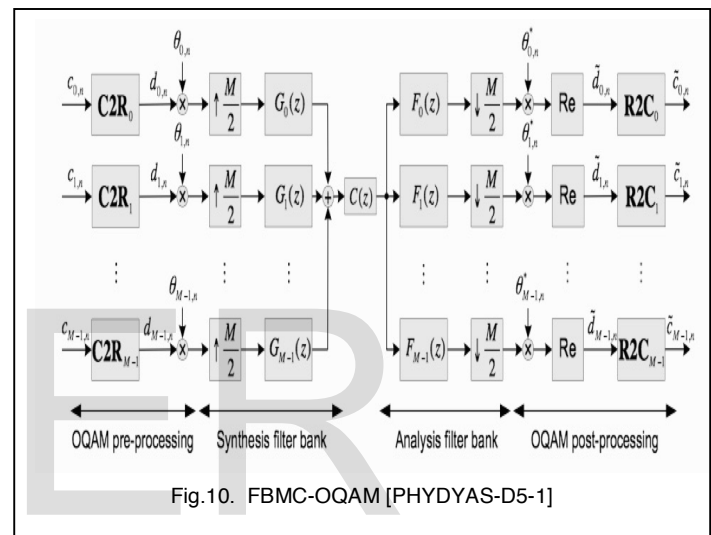

Fig.10. FBMC-OQAM [PHYDYAS-D5-1]

In the multiuser context, the sub-channels or groups of sub-channels allocated to the users are spectrally separated as soon as an empty sub-channel is present in-between. Therefore, users do not need to be synchronized before they gain access to the transmission system. This is a crucial facility for uplink in base station ruled networks or for future opportunistic communications. As the fig depicts, the filter bank based multicarrier (FBMC) modulation techniques, a synthesis-analysis filter bank structure can be considered to be the core of a system. The synthesis filter bank (SFB) consists of all parallel transmit filters and the analysis filter bank (AFB) includes the matching receive filters. Here, the focus is on uniform complex modulated filter banks where frequency shifted sub-channel filters of equal bandwidths are obtained from a single linear-phase low pass prototype filter $p[m]$ through exponential modulation. The complex I/Q baseband signal at the output of a SFB, a block diagram of which is shown in the figure above, [41] can be expressed as

$$s[m] = \sum_{k=0}^{M-1} \sum_{n=-\infty}^{\infty} d_{k,n} \theta_{k,n} \beta_{k,n} P \left[m - n \frac{M}{2} \right] e^{j \frac{2\pi k m}{M}}$$

Where

$$\theta_{k,n} = e^{j \frac{\pi}{2}(k+n)} = j^{k+n}$$

$$\beta_{k,n} = e^{-j \frac{2\pi}{M} k(L_p-1)}$$

The filters $G_k(z)$ are derived from prototype filter with real taps, by complex modulation at M equidistant frequencies. The efficient realization is made of IDFT and polyphase filtering. The filters $G_k(z)$ are related to prototype filter $p(m)$ as the following

$$g[m] = p[m] e^{j \frac{2\pi}{M} k \left(m - \frac{L_p-1}{2} \right)}$$

$$G_K[z] = p(z W_M^K) W_M^K \left(\frac{L_p-1}{2} \right)$$

Where, $W_M^K = e^{j \frac{2\pi}{M} K}$

The prototype filter can be decomposed to M polyphase components according to the following equation

$$P(z) = \sum_{j=0}^{M-1} z^{-j} P_j(z^M)$$

$$P[m] = \frac{1}{KM} \left(A[0] + 2 \sum_{k=1}^U (-1)^k A[k] \cos \left(\frac{2\pi k}{KM} (m+1) \right) \right)$$

$L_p=KM-1$: filter length, which depends on the size of the filter bank and the overlapping factor K . Here, m , M , $d_{k,n}$ and $\theta_{k,n}$ denote the sample index at high-rate (at the output of the SFB), the overall number of sub-channels, the real-valued symbol modulated (at rate $2/T$) on the k th subcarrier during the n th OQAM sub-symbol interval, and the phase mapping between the real-valued symbol sequence and the complex-valued input samples of the synthesis bank, respectively. The signaling interval T is defined as the inverse of the subcarrier spacing, i.e., $T = 1/\Delta f$. The C2R-blocks indicate the conversion from the real and imaginary parts of a complex valued symbol from a QAM alphabet into real-valued data. Symbols $d_{k,n}$ and $d_{k,n+1}$ can be interpreted to carry the in-phase and quadrature components, in an interleaved manner, with a relative time offset of $T/2$.

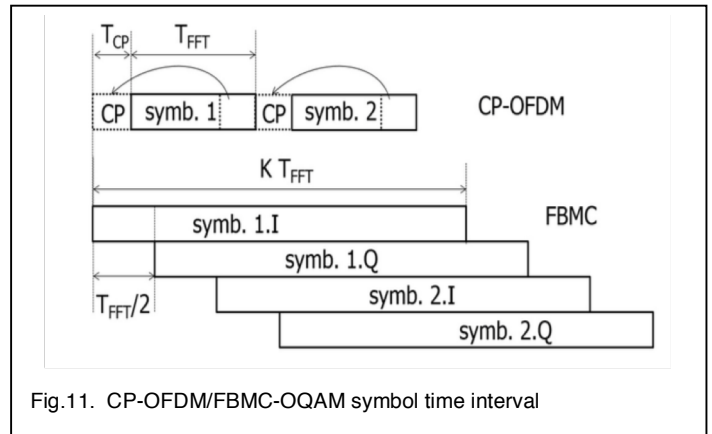

Fig.11. CP-OFDM/FBMC-OQAM symbol time interval

2.4 UF-OFDM OU UFMC

UFMC is a novel waveform technology, which aims at replacing the conventional Cyclic Prefix-based Orthogonal Frequency Division Multiplexing (CP-OFDM) and FBMC techniques. It is a generalization of OFDM and filter bank based multi-carrier (FBMC-FMT), which combines the advantages of OFDM and FBMC while avoiding its main drawbacks. UFMC is a very generic multicarrier scheme based on subband-wise filtering (detailed system model of UFMC in [43], [42]). In another word, in contrast to FBMC, UFMC applies a filtering functionality per sub-band instead of per subcarrier. The time-domain transmit vector x_k for a multicarrier symbol of user k is the superposition of the sub-band-wise filtered components, with filter length L and FFT length N , and can be represented by

$$\underbrace{x_k}_{[(N+L-1) \times 1]} = \sum_{i=1}^B \underbrace{F_{i,k}}_{[(N+L-1) \times N]} \cdot \underbrace{V_{i,k}}_{[N \times n_i]} \cdot \underbrace{S_{i,k}}_{[n_i \times 1]}$$

For the i -th subband ($1 \leq i \leq B$), the n_i complex QAM symbols are transformed to time-domain by the tall IDFT-matrix $V_{i,k}$, which includes the relevant columns of the inverse fourier matrix according to respective subband position within the overall available frequency range, $F_{i,k}$ is a Toeplitz matrix, composed of the FIR filter impulse response, performing the linear convolution, which is a design parameter, adjustable to propagation and time-frequency offset requirements [44]. UFMC is in its nature very close to OFDM. Instead of a CP, it uses soft symbol transitions, caused by per subband FIR filters, which filter groups of subcarriers.

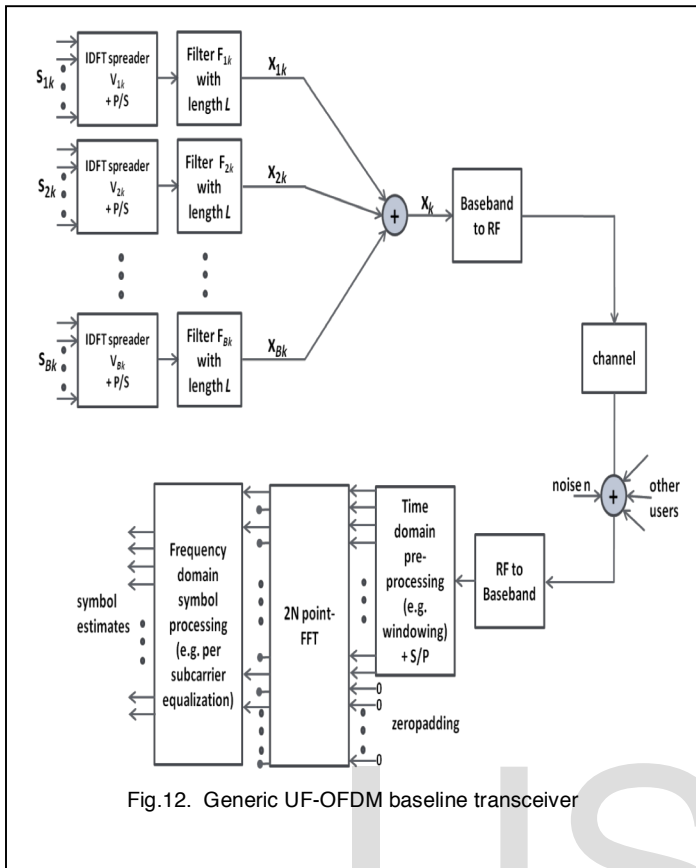

Fig.12. Generic UF-OFDM baseline transceiver

This approach, thus has much shorter filter lengths than FBMC, which makes UFMC more suitable to short burst communication [5]. Note that UF-OFDM with filter length 1 is identical to non-CP-OFDM. Due to this close relationship, reusing existing OFDM transceiver parts is easy. At the UF-OFDM receiver, after 2-N fast Fourier transform, picking each second output and dividing by the frequency response of the filter, yields the same frequency domain scalar per-subcarrier processing as in OFDM. As a result, all existing OFDM channel estimation algorithms can be directly reused by UF-OFDM. As UFMC is very close in nature to OFDM it is also called UF-OFDM [45]. For $n_i=1$ and $L \gg 1$, UF-OFDM converges to FBMC-FMT. UF-OFDM, due to its better spectral properties has shown to be much more robust against time-frequency misalignments than CP-OFDM [46]. As required in potential scenarios of 5G systems. This is advantageous for integrated 5G air interfaces for supporting synchronous broadband traffic in parallel to small packet services with relaxed synchronicity, i.e. less strict time-frequency alignment. This relaxed synchronicity helps to save signaling overhead and battery consumption, relaxes local oscillator requirements (helpful for low-end devices) and allows for a kind of “connection-less” operation mode. Furthermore, the improved spectral separation among subbands allows for the usage of different waveform parameters in parallel subbands, e.g. for supporting on a per-user basis special modes for low latency or high velocity. UF-OFDM employs Dolph-

Chebyshev filters as a feasible ad hoc choice, (with design parameters α (sidelobe attenuation) and filter order N) at the SBS to transmit data to the SMS. Dolph-Chebyshev filter minimizes the Chebyshev norm of the side lobes for the desired main lobe width, where the filter establishes the side lobes’ norm to $-\alpha$ dB. One notable property of Chebyshev window is that sidelobe attenuation remains same at all frequencies, which is unlike the filters employed in OFDM (rectangular window) and FBMC filter that have non-uniform side lobes attenuation feature. The function to be described is constructed using the well-known Chebyshev polynomials and was first used by Dolph [47] to solve the problem of designing a radio antenna having optimal directional characteristics [48]. The Chebyshev polynomials are defined by the equations

$$T_n(x) = \begin{cases} \cos(n \cos^{-1} x), & |x| < 1 \\ \cosh(n \cosh^{-1} x), & x \geq 0 \end{cases}$$

Based on the nth-order Chebyshev polynomials $T_n(\kappa)$ [49]

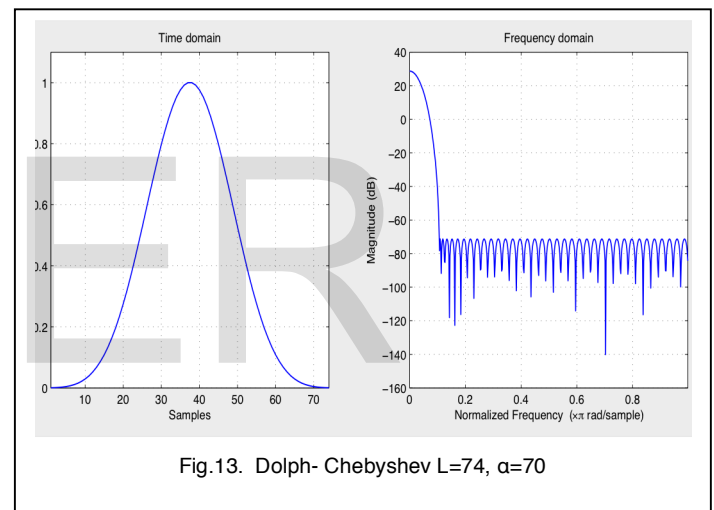

Fig.13. Dolph- Chebyshev L=74, $\alpha=70$

To sum up, UF-OFDM offers better spectral efficiency in time and band limited scenarios of about 10% [45] in CP-OFDM case and in conjunction with short burst lengths concerning FBMC. It also has several tens of dB lower spectral side lobe due the Dolph-Chebyshev filter (Fig.13). Owing to QAM modulation, UF-OFDM delivers full MIMO and CoMP support, key technologies for future systems, due to orthogonality in the complex plane, FBMC suffers from the lack of this complex orthogonality. e.g. complex pre-coding in conjunction with spatial multiplexing is not possible. UF-OFDM can be even used with different subcarrier spacings or filter times for users in different subbands. E.g. user 1 uses a particular FFT size N_1 and filter length L_1 , user 2 uses N_2 and L_2 and the UF-OFDM symbol durations might be designed identically, thus $N_1+L_1-1 = N_2+L_2-1$. This favors UF-OFDM to be a highly adaptive modulation scheme, which can be easily suitable and tolerated to many different aspects of communications such as delay/Doppler spread characteristics of the radio channel and user needs.

3 SIGNAL METRICS CHARACTERISTICS

3.1 Peak-to-Average Power Ratio (PAPR)

One of the significant drawbacks of multi-carrier modulation is the high peak-to-average power ratio (PAPR). In fact, the PAPR problem is one of the most detrimental aspects in the OFDM systems as it can cause power degradation and spectral spreading. But there are methods like DFT-precoding used in conjunction with CP-OFDM to build up single-carrier FDMA for bringing down PAPR. A low PAPR is of great importance for battery powered mobile terminals. The lower PAPR allows decreasing the power amplifier back-off, which in turn extends the operation time of a mobile terminal, at a certain transmission rate, compared to modulation schemes with a higher PAPR. Moreover, it enables to increase the coverage at cell edge. A high PAPR makes the PA work with large IBOs, resulting in inefficient use of the amplifier. It also, high PAPR, increases the complexity of the ADC and DAC.

To sum up, high PAPR signals are usually undesirable for it usually strains the analog circuitry. High PAPR signals would require a large range of dynamic linearity from the analog circuits, which usually results in expensive devices, and higher power consumption/lower efficiency (for example, power amplifier has to operate with larger back-off to maintain linearity), which is critical in case of satellite communications. The PAPR expression is as following:

$$PAPR = \frac{\max |x(n)|^2}{E\{|x(n)|^2\}}$$

Where $E\{\cdot\}$ denotes the expectation operation. PAPR increases proportionally with the number of subcarriers. Reducing $\max |x(n)|$ is the principle goal of PAPR reduction techniques. Statistically it is possible to characterize the PAPR using Complementary Cumulative Distribution Function (CCDF). It is the most common way to evaluate the PAPR by estimating the probability of PAPR when it exceeds a certain level. The CCDF expression of the PAPR of OFDM signals with relatively small subcarriers can be written as

$$\begin{aligned} CCDF &= P(PAPR > PAPR_0) \\ &= 1 - (1 - \exp(-PAPR_0))^N \end{aligned}$$

The PAPR characteristics of OFDM and FBMC are compared in [50], [51], [52]. The PAPR of OFDM and FBMC are shown to be similar for various scenarios in [51], [50], with FBMC providing lower spectral side lobes in its power spectral density. Similarly, [48] shows that FBMC and OFDM have practically identical PAPR cumulative distribution functions (CDFs). On the other hand, use of DFT-spreading, [50] and filter bank spreading [53] in conjunction with FBMC lowers the PAPR of the transmitted signals, yielding PAPRs that are close to those of SC-FDMA.

3.2 Cubic metric

Cubic metric (CM) has received an increasing attention because it is more closely related to the distortion induced by nonlinear

devices than the well-known peak-to-average power ratio (PAPR). Studies on PAPR and CM suggest that, except for large power back-off, CM is more closely related to the amount of distortion induced by a nonlinear power amplifier than PAPR [54]. Moreover, after analyzing certain OFDM-type signals that are considered to meet the goal of the long-term evolution (LTE), it was shown in the 3GPP that CM predicts amplifier power de-rating more accurately than PAPR [55]. The CM is described as

$$CM_{dB} = \frac{RCM_{dB} - RCM_{dB}^{ref}}{G}$$

$$RCM(s(t))_{db} = 10 \log_{10} \left(E \left\{ \left(\frac{|s(t)|^2}{E_s} \right)^3 \right\} \right)$$

Using a HPA, the third order distortions dominate, so the CM gives a better insight of the dynamic behavior of the signal in presence of odd order non-linearities.

3.3 Higher Power Amplifier (HPA)

One reason why the nonlinearity of PA should be considered seriously is that the large peak power of the multicarrier signal, sometimes makes the PA inefficient. PAPR relates to the power amplifier efficiency at the transmitter, and the maximum power efficiency is achieved when the amplifier operates at the saturation point. When adding up N subcarriers with the same phases, the peak power is N times than the average power of the signal on each subcarrier. This results in a high PAPR. Such associated problem with multicarrier signals is one of their principal drawbacks. Lower PAPR allows operation of the power amplifier close to saturation resulting in higher efficiency. With higher PAPR signal, the power amplifier operating point has to be backed off to lower the signal distortion, and thereby lowering amplifier efficiency. The non-linearity present in the amplifier can be expressed by its AM/AM component $F(s)$ and AM/PM component $\Phi(s)$, where s is the magnitude of the signal. Common non-linear devices found in practice are listed below:

3.3.1 Soft limiter (SL)

Most physical components do not exhibit piece-wise linear behavior. If the nonlinear element is linearized by a suitable pre-distorter, the SL can be a good model. The AM/AM and AM/PM nonlinear characteristics of a (SL) can be written as

$$F(s) = \begin{cases} s & s \leq A \\ A & s > A \end{cases}$$

3.3.2 Solid-state power amplifier

The input out relationship of many solid-state power amplifiers can be modeled as

$$F(s) = \frac{s}{\left(1 + \left(\frac{s}{A}\right)^{2p}\right)^{\frac{1}{2p}}}$$

$$\phi(s) = 0$$

Where the parameter P controls the smoothness of the transition from the linear region to the limiting or saturation region. When, $p \rightarrow \infty$ it converges to LS model.

3.3.3 Travelling-wave tube

The high-power amplifier (HPA) a Saleh-model can be found in [56].

$$F(s) = \frac{s}{1 + \left(\frac{s}{2A}\right)^2}$$

$$\phi(s) = \frac{\pi}{3} \frac{s}{s^2 + 4A^2}$$

The output signal $u(t)$ is formed as

$$u(t) = A(|s(t)|)e^{j(\varphi(s(t)) + \phi(|s(t)|))}$$

All these models give a maximum output signal of A. Input back off (IBO) used in these nonlinear devices can be defined in terms of A

$$IBO = 10 \log_{10} \left\{ \frac{A^2}{E|s(t)|^2} \right\}$$

The effect of hardware non-linearities has been studied in [57,58,60] Out of band power of OFDM signals increase, when amplified with nonlinear power amplifiers operating at lower back-offs. In [59], Zsolt Kollár and Péter Horváth showed that the non-linear amplifier adversely affects all modulations schemes, resulting in a similar spectral shape. The FBMC is severely affected by the non-linear distortion, but the resulting out-of-channel leakage is still lower compared to OFDM and DFTS-OFDM. The only exception is CE-OFDM which is resilient to the effect of the amplifier due to the constant envelope of the transmission signal. Impact of linear and non-linear PAs on the power spectral densities (PSDs) of OFDM and FBMC are modeled and compared in [50]. While FBMC has significantly lower sidelobes than those of OFDM when the PA operates in the linear region, the benefit of FBMC diminishes when the PA operates in the non-linear region. Since the user equipments closer to the cell edge have to transmit with higher power levels due to power control. Therefore, they may have to operate in the non-linear region of the PAs and benefit of using FBMC might be incremental for such users.

3.4 Carrier Frequency and Timing Offsets

In most communication systems, the baseband transmit signal is modulated onto a sinusoidal carrier via an oscillator. The receive signal is then demodulated, ideally using the same sinusoidal carrier. However, practical oscillators exhibit imperfections such as frequency offset and phase noise. Furthermore, the transmitter and receiver suffer from a timing offset. For instance, as simple example, let us denote with $x(t)$ the OFDM transmitted signal; the received signal $r(t)$ over AWGN channel can be written as

$$R(t) = e^{j2\pi\Delta f_0 t} x(t - \tau) + n(t)$$

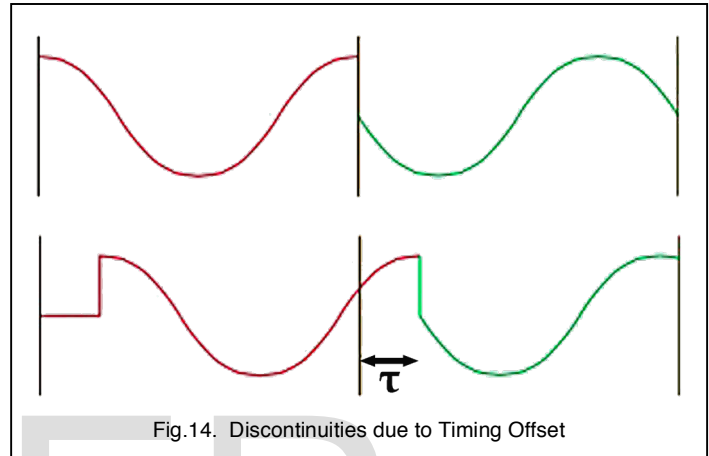

Fig.14. Discontinuities due to Timing Offset

CP- OFDM systems are very robust against positive timing offset as long as it is within the CP length. Once the timing offset exceeds the CP-length or it is negative (signal arrives earlier than the receiver expected), it starts to degrade the system performance. In contrast to OFDM, any timing offset in UFMC systems affect the system performance, since no CP is inserted. Even with a small timing offset, the orthogonality between subcarriers is destroyed, which causes ICI. In addition, the previous (positive delay) or subsequent (negative delay) symbol introduces ISI. Thus, the FIR-filter in UFMC has to be optimized to overcome the impact of carrier frequency offset and timing misalignment jointly [61]. The work in [5] introduces an open-loop based synchronization procedure for systems applying UFMC, called Autonomous Timing Advance (ATA). But the filter ramp-up and ramp-down indicates a soft protection against timing offset, since relatively small energy is contained. So, carefully multi-carrier parameter design can contribute in mitigation of ISI. The impact of multiuser synchronization errors including symbol timing offset and carrier frequency offset on the performance of OFDM and FBMC systems has been studied [62]. The amount of multiuser spectral leakage due to timing offset for any multicarrier waveform is closely related to the discontinuities in the observation window at the receiver. Moreover, filtering at both transmitter and receiver sides helps to mitigate the performance loss caused by the timing offset. Based on this discussion, it is clear that since UFMC adds a filtering operation to OFDM at the transmitter, it has a better ability to resolve the multi-user timing offset interference than OFDM. Moreover, FBMC can perform even better, thanks to its smooth filters both at the transmitter and receiver. In [63], the authors highlighted the fact that the linear FBMC has the least sensitivity to timing offset and carrier frequency offset.

3.5 Complexity

In fact, the key difference is the computational complexity; due to the size of the FFT, which is increased from M to KM and an issue, is how to reduce this complexity. Due to the overlapping in the time domain of the iFFT outputs and FFT inputs, a significant amount of redundancy is present in the computations. An efficient approach to reduce this redundancy is the so-called PPN-FFT scheme [29]. The additional complexity brought by the filter bank in the FBMC receiver can be expressed taking the FFT of the OFDM receiver as the reference. It depends on the number M of sub-channels in the system and the overlapping factor K. Assuming straightforward implementations, for M=256 and K=4, the filter bank in the FBMC receiver requires roughly 4 times more computations than the FFT of the OFDM receiver if the PPN-FFT scheme is employed and 8 times if the extended FFT scheme is employed. This additional complexity must be put in perspective and what is to be considered is its impact on the complexity of the entire system, including all the functions and, particularly, the iterative data recovering algorithms and error correcting codes.

For the UF-OFDM, the receiver complexity is modest: Slightly higher than factor 2 of CP-OFDM, as a 2-N point FFT is used for subcarrier demodulation. Regarding the UF-OFDM transmitter, so far only a matrix multiplication has been presented. This approach scales badly in terms of real multiplications and additions with O(N²), compared to the nice O(NlogN) scaling of N-point FFT implementations of CP-OFDM. The authors in [64] presented a multi-carrier modulator for enabling an efficient hardware implementation. It is frequency domain based and uses approximations for complexity savings. The solution uses adjustable parameters NIFFTo. Here reasonable values of e.g. NIFFTo = 64 lead to negligible approximation errors, as proved by assessing the mean squared error and the spectral properties

3.6 Delay

A key specification in digital transmission is the delay. An overall delay budget is allotted to the system and it is shared by the various functions in the transmitter and receiver. The main contributions come from modulation, optimal detection and error correction. In contrast, multicarrier techniques, particularly when filter bank based, consume a significant portion of the delay budget for modulation and demodulation. Therefore, there is a strong pressure to minimize the delay of the prototype filter (in the terminology of filter banks, the first filter in the bank, the filter associated with the zero-frequency carrier, is called the prototype filter, because the other filters are deduced from it through frequency shifts) and the selection of the number of coefficients L is a trade-off between delay and filter performance, mainly stop-band attenuation. The counterpart for the spectral separation provided by the filter banks is the introduction of a delay in the transmission, which, in some applications, must be considered when defining the systems and some of their parameters. The round-trip delay of an FBMC system is 2K multi-carrier symbol periods, twice the overlapping factor of the prototype filter. In burst transmission, if the spectra of the neighboring users have to be preserved, initial and final transition times are present and the burst is extended by K-1 symbol periods. Therefore, FBMC favors longer bursts.

3.7 Spectral efficiency

The spectral efficiency of the waveforms described here are given by:

$$\eta_{OFDM} = \frac{m \times N_{FFT}}{N_{FFT} + N_{CP}}$$

$$\eta_{UFDM} = \frac{m \times N_{FFT}}{N_{FFT} + L - 1}$$

$$\eta_{FDMC} = \frac{m \times S}{S + K - \frac{1}{2}}$$

$$\eta_{GFDM} = \frac{m \times P \times M}{P \times M + N_{CP}}$$

It is obvious to see that the use or avoidance of cyclic prefix affects the spectral efficiency of each waveform.

3.8 Channel estimation

A very basic issue arising from the fact of subcarriers spilling interference to its neighbors is associated with channel estimation: Let's a real pilot p, the actual symbol being transmitted on subcarrier k in symbol j (for simplicity we omit the index k,j in the following) is as follows:

$$P = p + jI$$

I is interference depending on the data surrounding the pilot subcarrier. So, after passing the channel H the received symbol is as follows:

$$Y = HP = H(p + jI)$$

The estimated channel is:

$$\tilde{H} = \frac{Y}{P} = H \left(1 + j \frac{I}{p} \right) = H + jH \frac{I}{p}$$

As the baseband representation H of the wireless channel typically is complex, there is no way to separate the estimate as easily as it is possible with the data. The so-called auxiliary pilot principle, is a very good means to overcome this issue, accompanies each pilot with another pre-calculated symbol cancelling the interference originating from adjacent data symbols. Naturally, a cost has to be paid as the auxiliary pilots require some energy reducing the available energy for the main pilot. So, if the systems are to be compared in a fair manner. The channel estimation is degraded accordingly compared to a system not requiring offset-QAM. To deal with this either complex multi-user receivers or capacity reducing guards have to be applied. However, any scheme relying on complex symbols are suffering

due to the inherent interference. In [65] showed that the use of filter bank multicarrier permits a robust estimation of very large propagation delays and of arbitrarily high carrier frequency offsets, whereas OFDM would have required a very long CP to attain the same performance levels.

4 MULTIPLE ACCESS TECHNIQUES

Multiple access schemes, the most fundamental aspect of the physical layer, to a large extent, are considered as the defining technical feature of each wireless communication generation [66,67]. As everyone knows that Machine Type Communications (MTC) and the Internet of Things (IoT) will be significantly important application for 5G. It is obviously that a new waveform study is required to support multiple access technology, or requires the joint design of waveforms and multiple access technologies. They have continually evolved in each cellular generation from FDMA, TDMA in 1G and 2G to CDMA in 3G and OFDMA/SC-FDMA for 4G. The key design targets for 5G multiple access techniques might be summarized in 1) Higher network spectral efficiency e.g. maximize spectral efficiency across users and enable MU-MIMO. 2) Link budget and capacity trade off. e.g. maximizing link budget and capacity by taking into consideration their trade off as well as the target use case requirements. 3) Lower overhead e.g. minimize protocol overhead to improve scalability, reduce power consumption, and increase capacity. In this section, we site some of the promising ones as candidate for 5G, which aim to boost further the spectrum efficiency.

4.1 NOMA

NOMA stands for non-orthogonal multiple access scheme. Boosting further the spectrum efficiency by increasing the complexity of receiver is its basic principle. This in mind, with the fast evolution of device processing capabilities exceeding Moore's law, it will become possible and ready to use in future practical systems. The key feature of NOMA is that multiple users will be allocated at different power levels, depending on their channel conditions, where it is worth pointing out that the communication with these users is happening at the same time, code and frequency channels. On the transmitter side, it is based on the utilization of non-orthogonal transmission so that it would intentionally introduce intra-cell and/or inter-cell interference. On the receiver side, multi-user signal separation is conducted based on successive interference cancellation (SIC), which is a gradual interference elimination strategy [68]. Judging the user individually in the received signal and processing signal amplitude recovery, then the multiple access interference (MAI) produced by this user could be subtracted from the received signal. Executing the same operation for the rest of the users could remove all the MAI. As any new technique, NOMA has pros and cons. An important advantage, is that the same channel can be shared by multiple users, thus it can improve the spectrum efficiency at the same transmission speed compared to 4G. Moreover, it is more easily to respond to various and changing link states by means of utilizing adaptive modulation and coding (AMC) and power-domain multiplexing technology, especially in high-speed mobile environment [69]. On the other hand, as it is a non-orthogonal transmission receiver is rather complex, SIC receiver design requires improvement in signal processing chip technology and the problem of

perfect elimination of MAI are some of its disadvantages.

In terms of analytical and system-level, the authors in [69,70] demonstrate that NOMA can achieve better spectral efficiency compared to other orthogonal multiple access techniques, such as time division multiple access (TDMA), orthogonal frequency division multiplexing (OFDM) and code division multiple access (CDMA). Moreover, the authors in [71] showed that the system-level performance achieved by NOMA is higher by more than 30% compared to OMA (Orthogonal Multiple Access). Also, in [72], in uplink scheme, the spectral efficiency was improved by nearly 20%.

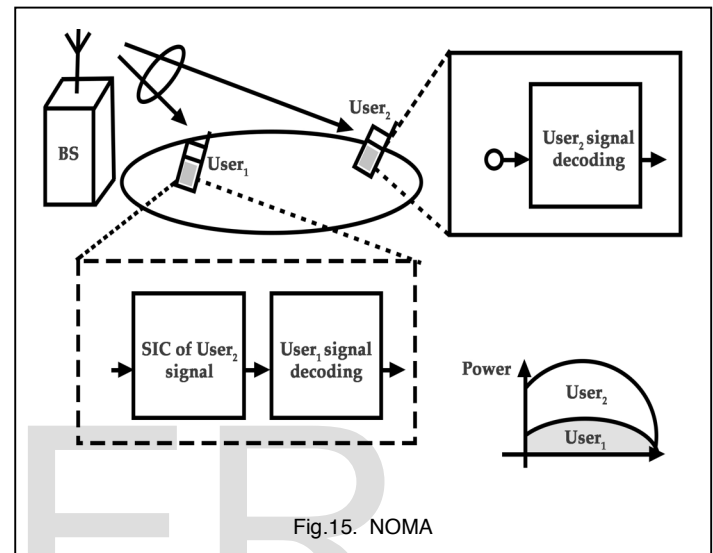

Fig.15. NOMA

4.2 SCMA

Spectrum is a very scarce commodity and it should be exploited as efficiently as possible. The desired increase in communication speed requires smarter and more complicated communication algorithms that can exploit the available resources through various multiple access methods, as efficiently as possible. Currently, the following resources are available: Time, Frequency, Code and Space. To improve spectrum efficiency, it is desirable to come up with the spatial and code domain besides time and frequency domain. Among the issues that arise due to massive connectivity is the cost of signaling overhead and latency. In this direction, Huawei proposed Sparse Code Multiple Access (SCMA), in which multiple users access the same channel with user-specific sparse codewords. It has attracted much attention since it is capable of supporting massive connections simultaneously, yielding a competitive candidate for Fifth Generation (5G) communications [73]. Commonly, SCMA can be viewed as a generalization of sparse spread CDMA [74], with a few numbers of nonzero elements within a signature. In SCMA, the procedure of bit to QAM symbol mapping and spreading are combined together and incoming bits are directly mapped to a multidimensional code work of an SCMA codebook set and each layer or user has its dedicated codebook.

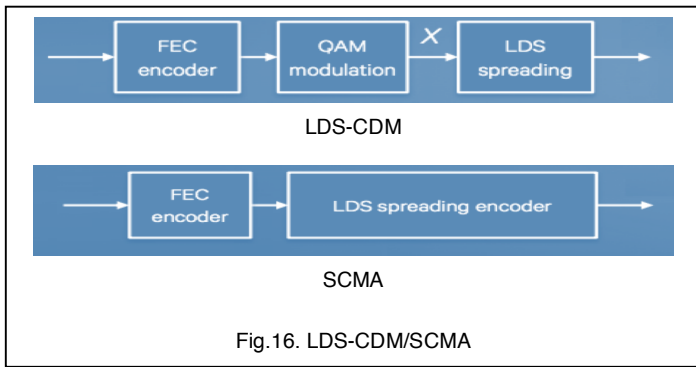

Fig.16. LDS-CDM/SCMA

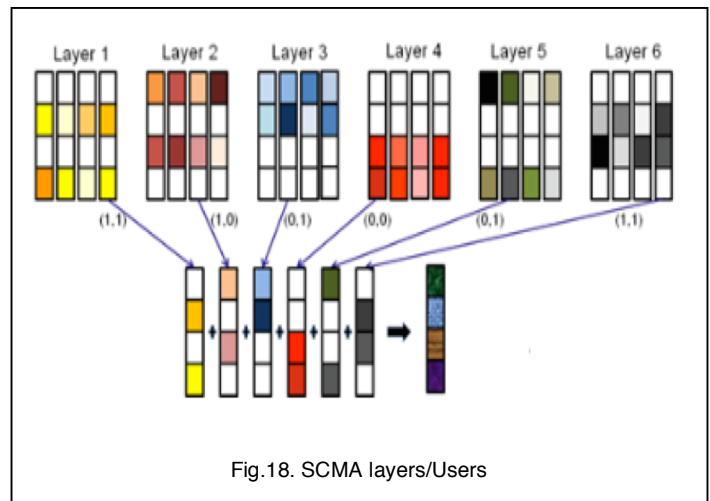

Fig.18. SCMA layers/Users

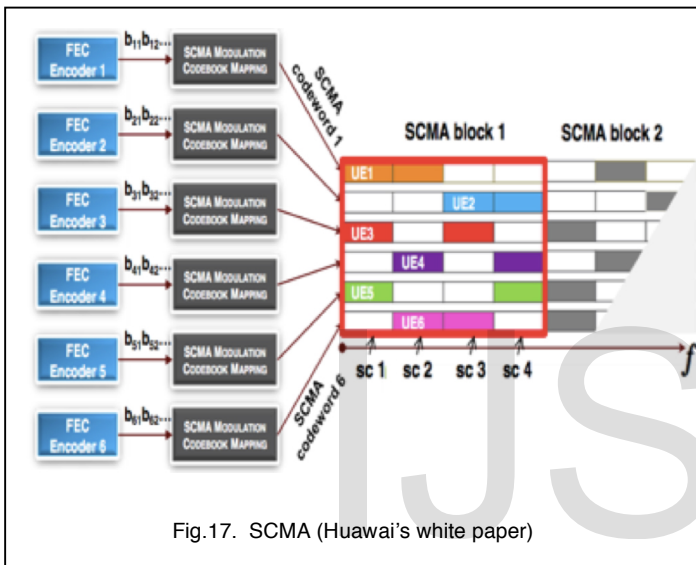

Fig.17. SCMA (Huawei's white paper)

The sparsity pattern can be build as

0	1	1	0	1	0
1	0	1	0	0	1
0	1	0	1	0	1
1	0	0	1	1	0

For an uplink SCMA system, when each user is assigned a specific codebook, the multiplexing becomes a superposition scheme, which will obtain the shaping gain. However, on the receiver side serious multiple address interference (MAI) is the main obstacle to implement multiuser detection. The optimum maximum a posteriori (MAP) algorithm obviously shows the best performance with considerable complexity. In order to tackle the high complexity of MAP algorithm, some low complexity algorithms are proposed to handle this NP-complete problem [68] within tolerable performance loss. Especially, thanks to the sparse structure of SCMA, the complex MAP formula can be solved iteratively with sum product algorithm or message passing algorithm (MPA) [75]. Hence, the better performance of SCMA can be explained by the fact that SCMA is able to allow for more signal overlapping or user collisions due to the sparsity of the SCMA codewords and the better blind multiuser detection with MPA algorithm [76].

The maximum number of codebooks, J , that can be generated is a function of N (non-zero entries in a codeword) and K (codeword length). Selection of N non-zero positions within K elements is simply a combination problem. The maximum number of such combinations is given by the binomial coefficient as follows

$$J = \binom{K}{N}$$

By multiplexing codewords (each from the codebooks) over resources, the overloading factor (OF) is defined as:

$$OF = \frac{1}{K}$$

By adjusting the spreading factor, K , and the number of non-zero entries, N , different levels of overloading can be achieved with different number of codebooks. In order to support massive connectivity, it is desired to have an overloading factor much greater than 1.

To sum up, SCMA is a multi-dimensional codebook-based non-orthogonal spreading technique. In SCMA, the procedure of bit to QAM symbol mapping and spreading are combined together and incoming bits are directly mapped to multi-dimensional codewords of SCMA codebook sets e.g SCMA replaces QAM modulation and LDS spreading with multi-dimensional codebooks. This enables SCMA to benefit from shaping or coding gains as one of the main sources of the performance improvement in comparison to the simple repetition of QAM symbols in LDS. It also enjoys the low complexity reception techniques due to the sparsity of SCMA codewords. With the fact that it is relatively easy to be implemented and the multiple access techniques designed and improved based on it can absolutely be applied into the uplink and downlink of 5G wireless networks.

Even though the design and optimization of the code are challenging as the structure of the code is well defined. In [73] a sub-optimal design methodology is proposed based on a multi-stage optimization approach. Thus, SCMA has several advantages as follows:

- 1) Overloading increases overall throughput and connectivity;
- 2) Sparsity helps to reduce the complexity of detection;
- 3) Multi-dimensional codewords bring shaping gain and better spectral efficiency;
- 4) Spreading with factor K helps to achieve robust link adaptation.

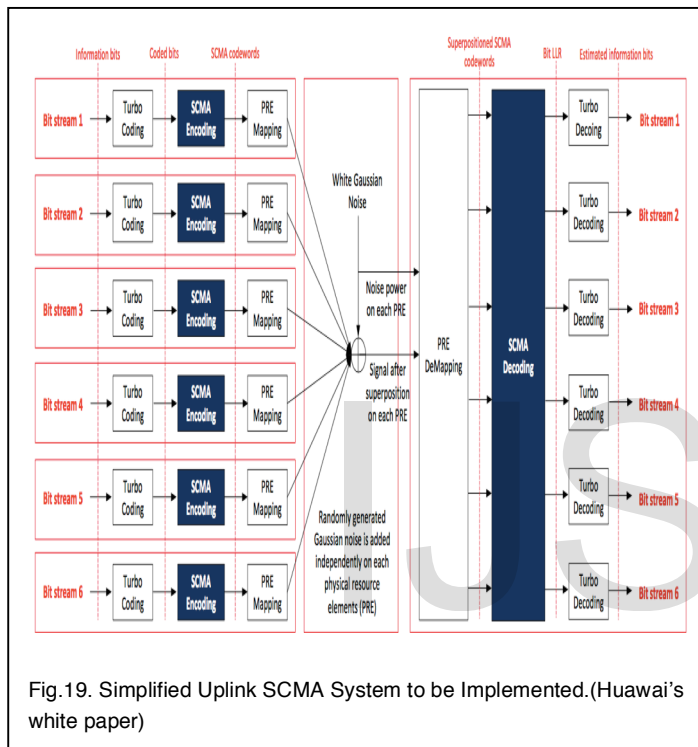

Fig.19. Simplified Uplink SCMA System to be Implemented. (Huawei's white paper)

Here in the figure the turbo coding/decoding can be replaced by other forward error correction.

4.3 MUSA

MUSA, stands for Multi-user Shared Access, was first proposed by ZTE and it is based on spreading sequences and advance SIC. In this way, multiple user data are respectively spread by the special spreading sequences, then each user's data spread are overlapped to be transmitted, it uses advanced SIC receiver to demodulate and recover the data of each user at the receiving end. In contrast, most traditional communication technologies use orthogonality to distinguish users, that is, different users are assigned different time, sub-carrier, or space, which could avoid overlapping each other. MUSA assigns a new spreading sequence for each user, then these users are assigned at the same time, sub-carrier, or space. Compared with the traditional code division multiple access, the spreading sequence used by

MUSA can be non-orthogonal, which is just for spreading spectrum. Consequently, MUSA needs to make use of the technology of SIC receiver to distinguish the different user's signal. In the energy point of view, MUSA does not need synchronization in principle which is critical to improve the battery life. Owing to the aforementioned, the technology of MUSA uplink is very suitable for the Internet of Things (IoT). [77].

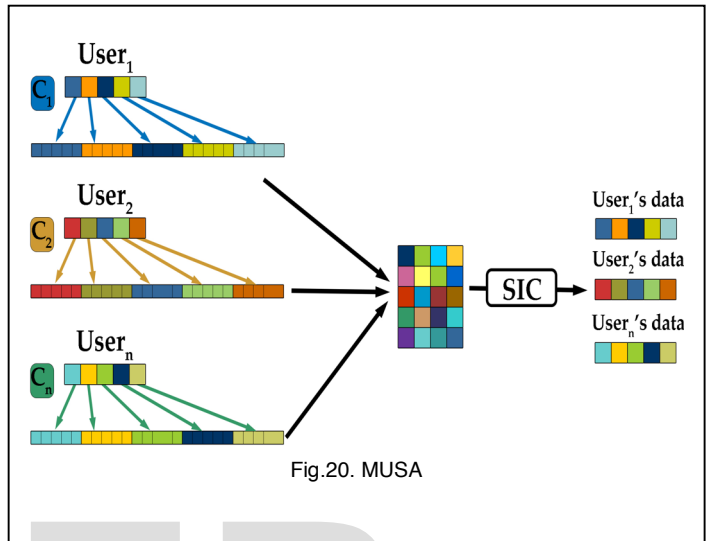

Fig.20. MUSA

To resume, MUSA ensures the great system capacity, the balance between the users at the same time in a relatively relaxed condition so greatly simplifies the system implementation, shortens the access time of mass access and reduces energy consumption of terminals.

4.4 PDMA

As another novel non-orthogonal multiple access scheme to add to the list. Pattern Division Multiple Access (PDMA) takes joint/holistic design of SIC-amenable pattern at the transmitter and low-complexity quasi-ML SIC detection at the receiver [78]. It offers a balance between diversity degree and multiplexing. At transmitter, multiple users are distinguished by non-orthogonal characteristic pattern in single or multiple signal domains, such as power domain, space domain and code domain. At receiver, multiple users can get equivalent diversity degree after SIC amenable detection Fig21 As the Internet of Things (IoT) will be a major player and MIMO as a key technology for the future networks, PDMA still faced with some key problems to be solved such as how to design patterns at transmitter to distinguish users more easily, how to simplify receiver, how to combine PDMA with MIMO.

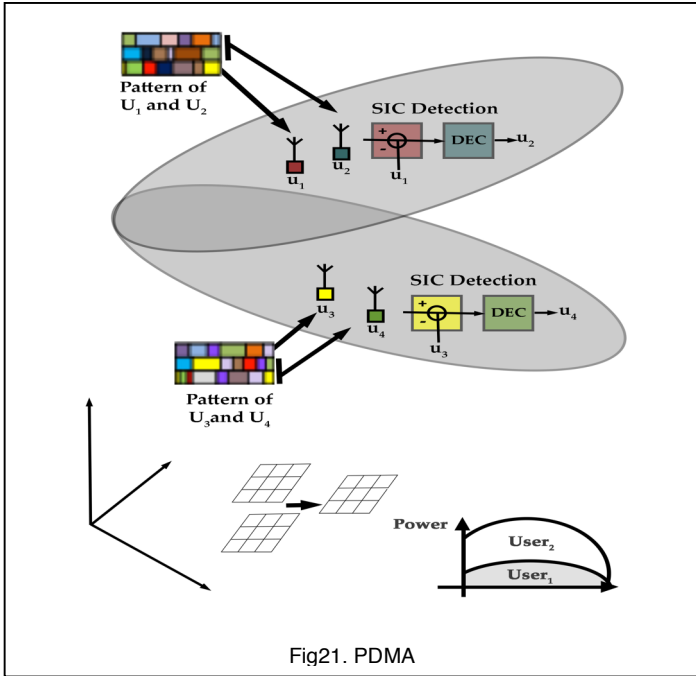

Fig21. PDMA

4.5 IDMA

As well known in the literature, Code Division Multiple Access (CDMA) is tolerant to strong interference and can accommodate multiple signal layers, by exploiting the orthogonal user-specific signal signatures. However, the performance of CDMA systems both in uplink and downlink can be negatively influenced by a slight asynchronous communication. Interleave-Division Multiple-Access (IDMA) aims to maintain the performance of the CDMA system, if the multiple users lose synchronicity, and was first proposed by Li Ping et al [79] [80]. The scheme considered is a special case of CDMA in which bandwidth expansion is entirely performed by low-rate coding. It is a user-specific interleavers based for multiple users independently, in which users are distinguished by different chip-level interleavers instead of by different signatures as in a conventional CDMA system incorporating the principle explained in [81]. For low rate channel encoding/decoding, repetition coding can be optionally integrated into the IDMA system, to emulate low rate channel codes. It also allows a low complexity multiple user detection techniques applicable to systems with large numbers of users in multipath channels. It uses Elementary Signal Estimator (ESE) or soft rake detector, which is a result of the combination of Forward Error Correction (FEC) and user-specific interleaving e.g a turbo-type multi-user detector for IDMA. With the fact that asynchronous traffic, such as originated by sensors, will play a more and more important role in future wireless communication standards. IDMA attracts more and more attentions in combination with multi-carrier systems [82], [83].

Owning to the aforementioned, the integration of IDMA to 5G

systems, preferably in conjunction with a multicarrier waveform would be of great benefits. For more insight, the reader is urged to refer to the reference herein in this section.

4.6 Bit Division Multiplexing (BDM)

Bit division multiplexing (BDM) was recently proposed in [84] aiming to improve the throughput of a broadcasting system that supports the transmission of multiple services with differentiated minimum signal-to-noise ratios (SNRs) required for successful receptions simultaneously. It can be simply seen as an instantiation of ideal superposition coding and can be regarded as an extension of conventional hierarchical modulation. BDM outperforms the conventional time division multiplexing (TDM) counterpart by extending the multiplexing from symbol level to bit level. Benefiting from multiple error protection levels of bits within each high-order constellation symbol, BDM can provide so-called nonlinear allocation of the channel resources. By allocating channel resource at bit level, BDM could achieve higher overall transmission rate or lower minimum SNR requirement in multi-service broadcasting. Moreover, the authors in [85] showed that BDM works with MIMO, the key technology for future systems, which makes the technique attractive.

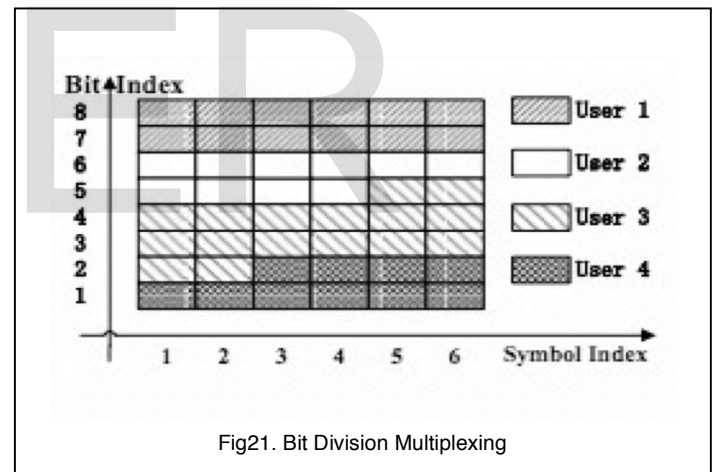

Fig21. Bit Division Multiplexing

4 CONCLUSION

In this work, we have presented an overview of some promising waveforms, multiple access technology and channel code candidates for 5G future systems. The fact that Mobile Internet and Internet of Things are widely identified as the two major driving forces for 5G. It is an exciting time in the wireless industry and for wireless research at large. The future network will focus on the different business applications and user experience other than just the pursuit of the greater bandwidth and volume. This will raise the requirement to build service oriented networks to quickly and efficiently respond to user needs, as well as to offer consistent and high-quality services for different use cases and scenarios, which include dense residential areas, stadiums, open-air gatherings, subways, highways, high-speed railways, and wide-area coverage and, characterized by ultra-

high traffic volume density, ultra-high connection density, or ultra-high mobility. This can be done by a creative thinking and a sense of urgency in bringing innovative new technologies into reality. With other key technologies such as Full Duplex, MIMO, mmWave, researchers globally are working hard with industries towards the goal that is the design of an air interface that is adaptable to the diverse services, applications and devices of the future, scalable to support massive connectivity and massive capacity and intelligent to adapt to all the locally available spectrum which is likely to be standardized by the end of 2018 and be rolled out from 2020. It is a long road ahead to truly disruptive 5G networks. Many technical challenges remain spanning all layers of the protocol stack and their implementation, as well as many intersections with regulatory, policy, and business considerations. In addition, the physical technology to create the radio signal remains a fundamental challenge. RF circuits face a range of challenges including: high-power amplifier nonlinearity, crosstalk, leaky passive filters, antenna coupling, low noise amplifier (LNA) saturation, to name just a few.

5 ACKNOWLEDGMENT

The authors would like to acknowledge the support of EU-Metalic Erasmus Mondus Scholarship program and Bologna University. We would like to thank Ms Lieke Koopman for her help with the design of some figures on this work.

6 REFERENCES

- [1] S. Haykin, "Cognitive radio: Brain-empowered wireless communications," *IEEE J. Select. Areas Commun.*, vol. 23, no. 2, pp. 201–220, Feb. 2005
- [2] T. Jiang, W. Xiang, H. H. Chen, and Q. Ni, "Multicast broadcasting services support in OFDMA-based WiMAX systems," *IEEE Communications Magazine*, vol. 45, no. 8, pp. 78–86, Aug. 2007.
- [3] H. Ochiai and H. Imai, "On the distribution of the peak-to-average power ratio in OFDM signals," *IEEE Trans. Commun.*, vol. 49, no. 2, pp. 282–289, Feb. 2001.
- [4] IMT-2020 (5G) Promotion Group. 5G vision and demand.2014.5.
- [5] F. Schaich and T. Wild, "Relaxed Synchronization Support of Universal Filtered Multi-Carrier including Autonomous Timing Advance," *IEEE Int. Symp. on Wireless Commun. Syst. (ISWCS)*, Barcelona, August 2014.
- [6] G. Wunder et al., "5G NOW: non-orthogonal, asynchronous waveforms for future mobile applications," *IEEE Commun. Mag.*, vol. 52, no. 2, pp. 97–105, February 2014.
- [7] G. Wunder et al., "5G NOW: Challenging the LTE Design Paradigms of Orthogonality and Synchronicity," *IEEE Veh. Technol. Conf. Spring (VTC Spring) Workshop*, Jun. 2013
- [8] S. Whitehead, "Adopting Wireless Machine-to-Machine Technology," *IEE Journal of Computing and Control Engineering*, vol. 15, no. 5, pp. 40–46, Oct-Nov. 2004.
- [9] G. Wu, S. Talwar, K. Johansson, N. Himayat, and K. Johnson, "M2M: From Mobile to Embedded Internet," *IEEE Commun. Mag.*, vol. 49, no. 4, pp. 36–43, Apr. 2011.
- [10] X. Li et al., "Smart Community: An Internet of Things Application," *IEEE Commun. Mag.*, vol. 49, no. 11, pp. 68–75, Nov. 2011.
- [11] A. Aijaz and A. H. Aghvami, "Cognitive Machine-to-Machine Communications for Internet-of-Things: A Protocol Stack Perspective" *IEEE Internet of Things Journal*, vol. 2, no. 2, pp. 103–112, Apr. 2015.
- [12] F. Boccardi, R. Heath, A. Lozano, T. Marzetta, and P. Popovski, "Five Disruptive Technology Directions for 5G," *IEEE Commun. Mag.*, vol. 52, no. 2, pp. 74–80, Feb. 2014.
- [13] G. Fettweis and S. Alamouti, "5G: Personal Mobile Internet Beyond What Cellular Did to Telephony," *IEEE Commun. Mag.*, vol. 52, no. 2, pp. 140–145, Feb. 2014.
- [14] Y. G. Li and G. L. Stuber, Eds., "Orthogonal Frequency Division Multiplexing for Wireless Communications". Springer, 2006, ch. Peak Power Reduction Techniques, pp. 199–244.
- [15] Xiaodong Li and Leonard J. Cimini, Jr. "Effects of Clipping and Filtering on the Performance of OFDM", *IEEE COMMUNICATIONS LETTERS*, VOL. 2, NO. 5, MAY 1998.
- [16] S. H. Han and J. H. Lee, "An Overview of Peak-to-average Power Ratio Reduction Techniques for Multicarrier Transmission," *IEEE Wireless Commun. Mag.*, pp. 56–65, Apr. 2005.
- [17] Horizon2020-Advanced 5G Networks Infrastructure for future Internet PPP—www.Networks.eu
- [18] Horizon2020-5G Infrastructure PPP—Prestructuring model RTD&INNO strands—www.5g-ppp.eu
- [19] M. Morelli, "Timing and frequency synchronization for the uplink of an OFDMA system," *IEEE Trans. Commun.*, vol. 52, no. 2, pp. 296–306, Feb. 2004
- [20] T. Hwang, C. Yang, G. Wu, S. Li, and G. Ye Li, "OFDM and its wireless applications: A survey," *IEEE Trans. Veh. Technol.*, vol. 58, no. 4, pp. 1673–1694, May 2009
- [21] R. Irmer, H. Droste, P. Marsch, M. Grieger, G. Fettweis, S. Brueck, H.-P. Mayer, L. Thiele, and V. Jungnickel, "Coordinated multipoint: Concepts, performance, and field trial results," *IEEE Commun. Mag.*, vol. 49, no. 2, pp. 102–111, Feb. 2011.
- [22] Fettweis,G.; Krondorf,M.; Bittner,S., "GFDM-Generalized Frequency Division Multiplexing," *IEEE Vehicular Technology Conference, VTC Spring 2009*, IEEE 69th, pp.1-4, 26-29 April 2009.
- [23] A. Seyedi and G. Saulnier, "General ICI Self-Cancellation Scheme for OFDM Systems," in *IEEE Transactions on Vehicular Technology*, vol. 54, no. 1, Jan. 2005.
- [24] Y. Zhao and S. Haeggman, "Intercarrier Interference Self-Cancellation Scheme for OFDM Mobile Communication Systems," *IEEE Transactions on Communications*, vol. 49, no. 7, 2001.
- [25] H. Ma and J. Wolf. On Tail Biting Convolutional Codes, *IEEE Transactions on Communications*, Vol: 34, Issue: 2, Feb 1986.
- [26] R. Habendorf, R. Irmer, W. Rave and G. Fettweis. "Nonlinear Multiuser Precoding for non-connected Decision Regions" in *Proc. 6th Workshop Signal Process. Adv. Wireless Commun.*, Jun. 2005, New York City, USA.
- [27] Datta, R., et al. "Generalized Frequency Division Multiplexing in cognitive radio". *Signal Processing Conference (EUSIPCO)*, 2012 Proceedings of the 20th European. 2012, IEEE: Bucharest. p. 2679-2683.
- [28] Nicola Michailow, Maximilian Matthé, Ivan Simões Gaspar, Ainoa Navarro Caldevilla "Generalized Frequency Division Multiplexing for 5th Generation Cellular Networks" *IEEE TRANSACTIONS ON COMMUNICATIONS*, VOL. 62, NO. 9, SEPTEMBER 2014
- [29] European Union's 7th Framework Programme: Project PHY-DYAS (PHYSical layer for DYnamic AccesS and cognitive radio), Project website: www.ist-phydyas.org.
- [30] M. Bellanger, "Specification and Design of a Prototype Filter for Filter Bank Based Multicarrier Transmission," in *Proc. ICASSP*, Salt Lake City, USA, May 7-11. 2001, pp. 2417–2420.
- [31] R. W. Chang, "Synthesis of band-limited orthogonal signals for multichannel data transmission," *The Bell System Technical J.*, pp. 1775–1796, Dec. 1966.
- [32] B. Saltzberg, "Performance of an efficient parallel data transmission system," *IEEE Trans. Commun. Technol.*, vol. 15, no. 6, pp. 805–811, Dec. 1967.

- [33] T.Karpand N.J.Fliege, "Modified DFT Filter Banks with Perfect Reconstruction," *IEEE Trans. on Circuits and Systems II*, vol. 46, pp. 1404–1414, Nov. 1999
- [34] P. Siohan, C. Siclet, and N. Lacaille, "Analysis and Design of OFDM/OQAM Systems Based on Filter Bank Theory," *IEEE Trans. on Signal Proc.*, vol. 50, pp. 1170–1183, May. 2002.
- [35] V. Vakilian, T.Wild, F.Schaich, S.stenBrink, and J.F.Frigon, "Universal Filtered Multi-Carrier Technique for Wireless Systems Beyond LTE," in *Proc. IEEE Globecom Workshop*, Atlanta, Dec. 2013.
- [36] M. Bellanger, "Efficiency of Filter Bank Multicarrier Techniques in Burst Radio Transmission," *Global Telecommunications Conference (GLOBECOM 2010)*, 2010 IEEE, vol., no., pp.1,4, 6-10 Dec. 2010.
- [37] P. Chu, "Quadrature mirror filter design for an arbitrary number of equal bandwidth channels," *Acoustics, Speech and Signal Processing*, *IEEE Transactions on*, vol. 33, pp. 203–218, Feb 1985.
- [38] Farhang-Boroujeny, B., "OFDM Versus Filter Bank Multicarrier," *Signal Processing Magazine*, *IEEE*, vol.28, no.3, pp.92,112, May 2011.
- [39] M. Bellanger, "Physical layer for future broadband radio systems," *Radio and Wireless Symposium (RWS)*, 2010 IEEE, vol., no., pp.436,439, 10-14 Jan. 2010.
- [40] Ndo, G.; Hao Lin; Siohan, P., "FBMC/OQAM equalization: Exploiting the imaginary interference," *Personal Indoor and Mobile Radio Communications (PIMRC)*, 2012 IEEE 23rd International Symposium on, vol., no., pp.2359,2364, 9-12 Sept. 2012.
- [41] A. Viholainen, T. Ihalainen, T. Hidalgo Stitz, M. Renfors, and M. Bellanger, "Prototype Filter Design for Filter Bank Based Multicarrier Transmission," in *Proc. EUSIPCO*, Glasgow, Scotland, August 24-28. 2009.
- [42] F. Schaich, T. Wild, and Y. Chen, "Waveform contenders for 5G - suitability for short packet and low latency transmissions," in *Proc. IEEE VTC Spring*, Seoul, April 2014.
- [43] F. Schaich and T. Wild, "Waveform contenders for 5G - OFDM vs. FBMC vs. UFMC," *Int. Symp. on Commun, Control and Signal Process. (ISCCSP)*, Athens, April 2014.
- [44] Wang, X.; Wild, T.; Schaich, F.; "Filter Optimization for Carrier Frequency and Timing Offsets in Universal Filtered Multi-Carrier System", *IEEE ISWCS14*, Barcelona, August 2014.
- [45] Schaich, F.; Wild, T.; Chen, Y.; "Waveform contenders for 5G-suitability for short packet and low latency transmissions," in *proc. IEEE Veh. Technol. Conf. Spring (VTC'14 Spring)*, May 2014.
- [46] Wild, T.; Schaich, F.; Chen, Y.; "5G Air Interface Design based on Universal Filtered (UF-)OFDM," in *proc. DSP14*, Hongkong, Aug. 2014.
- [47] Dolph, C. L., "A current distribution for broadside arrays which optimizes the relationship between beam width and side-lobe level". In *Proc. IRE*, 1946. 34, 335–348.
- [48] Kraus, J. D., 1988: *Antennas*. 2d ed. McGraw-Hill, 892 pp.
- [49] P. Lynch, "The Dolph-Chebyshev Window: A Simple Optimal Filter" *Monthly Weather Review*, vol. 125, no. 1, pp. 655-660, Apr. 1997.
- [50] T. Ihalainen, A. Viholainen, T. Stitz, M. Renfors, and M. Bellanger, "Filter bank based multi-mode multiple access scheme for wireless uplink," in *Proc. European Signal Processing Conf. (EUSIPCO)*, vol. 9, Glasgow, Scotland, Aug. 2009, pp. 1354–1358.
- [51] D. Waldhauser, L. Baltar, and J. Nassek, "Comparison of filter bank based multicarrier systems with OFDM," in *Proc. IEEE Asia Pacific Conf. on Circuits and Systems*, Singapore, Dec. 2006, pp. 976–979.
- [52] Z. Kollar and P. Horvath, "Physical layer considerations for cognitive radio: Modulation techniques," in *Proc. IEEE Veh. Technol. Conf. (VTC)*, Budapest, Hungary, May 2011, pp. 1–5.
- [53] M. Bellanger, "FS-FBMC: an alternative scheme for filter bank based multicarrier transmission", *Proceedings of the 5th International Symposium on Communications, Control and Signal Processing, ISCCSP 2012*, Rome, Italy, 2-4 May 2012
- [54] A. Behravan and T. Eriksson, "Some statistical properties of multicarrier signals and related measures," in *Proc. IEEE Veh. Technol. Conf. Spring*, vol. 4, May 2006, pp. 1854-1858
- [55] 3GPP TSG RAN WG1, TDoc R1-060023, "Cubic metric in 3GPP-LTE," Jan. 2006.
- [56] A. Saleh: Frequency-Independent and Frequency-Dependent Nonlinear Models of TWT Amplifiers, *IEEE Trans. Commun.*, Vol. 29, pp. 1715-1720, Nov. 1981
- [57] R. Grossand D. Veeneman, "Clipping distortion in DMT systems," *IEEE lect.Lett.*, vol.29, no. 24. pp. 2080-2081, 1993.
- [58] M. Friese, "On the degradation of OFDM-signals due to peak-clipping in optimally predistorted power amplifiers," in *IEEE GLOBECOM*, pp.936-944, Sydney, Australia, 1998.
- [59] Z. Kollár, P. Horváth, "Physical Layer Considerations For Cognitive Radio: Modulation Techniques", *IEEE 73rd Vehicular Technology Conference (VTC Spring)*, Yokohama, 2011.
- [60] A. D. S. Jayalath and C. Tellambura, "Reducing the out of Band Radiation of OFDM Using an Extended Guard Interval", *54th IEEE Vehicular Technology Conference*, Atlantic City, NJ 2001.
- [61] Xiaojie Wang, Thorsten Wild, and Frank Schaich, "Filter Optimization for Carrier-Frequency and Timing Offset in Universal Filtered Multi-Carrier Systems" *IEEE, 81st Vehicular Technology Conference (VTC Spring)*, Glasgow, 2015.
- [62] T.Fusco, A.Petrella, and M.Tanda, "Sensitivity of multi-user filter-bank multicarrier systems to synchronization errors," in *Communications, Control and Signal Processing*, 3rd International Symposium on. *IEEE*, 2008, pp. 393–398
- [63] Amir Aminjavaheri, Arman Farhang, Ahmad Rezazadeh Reyhani and Behrouz Farhang-Boroujeny, "Impact of Timing and Frequency Offsets on Multicarrier Waveform Candidates for 5G", *2015 IEEE Signal Processing and Signal Processing Education Workshop (SP/SPE)*.
- [64] Thorsten Wild and Frank Schaich "A Reduced Complexity Transmitter for UF-OFDM" *IEEE 81st Vehicular Technology Conference (VTC Spring)*, Glasgow, 2015.
- [65] N. Cassiau, D. Ktenas, and J.-B. Dore, "Time and frequency synchronization for CoMP with FBMC," in *Proc. 10th Int. Symp. Wireless Commun. Syst.*, Aug. 2013, pp. 1–5.
- [66] T. Cover and J. Thomas, *Elements of Information Theory*, John Wiley and Sons, 1991.
- [67] David Tse and Pramod Viswanath, *Fundamentals of Wireless Communication*, Cambridge University Press, 2005.
- [68] S. Verdu, *Multiuser detection*. Cambridge University Press, 1998.
- [69] Y. Saito, A. Benjebbour, Y. Kishiyama and T. Nakamura. "System-level performance evaluation of downlink non-orthogonal multiple access (NOMA)". *Personal Indoor and Mobile Radio Communications (PIMRC)*, 24th International Symposium on London, United Kingdom: *IEEE*, 2013. 611.
- [70] Y. Saito, Y. Kishiyama, A. Benjebbour, et al. "Non-Orthogonal Multiple Access (NOMA) for Cellular Future Radio Access". *IEEE 77th Vehicular Technology Conference (VTC Spring)*, 2013.
- [71] M. Al-Imari, P. Xiao, M. A. Imran and R. Tafazolli. "Uplink non-orthogonal multiple access for 5G wireless networks". *11th International Symposium on Wireless Communications Systems*, Barcelona *IEEE*, 2014.
- [72] A. Benjebbour, Y. Saito, Y. Kishiyama, et al. Concept and practical considerations of non-orthogonal multiple access (NOMA) for future radio access. *International Symposium on Intelligent Signal Processing and Communication Systems*, 2013: 770.
- [73] H. Nikopour and H. Baligh, "Sparse code multiple access," in *Proc. IEEE 24th Int'l. Symp. Personal Indoor & Mobile Radio Commun.*, 2013.
- [74] D. Guo and C.-C. Wang, "Multiuser detection of sparsely spread CDMA," *IEEE J. Sel. Areas Commun.*, vol. 26, no. 3, pp. 421–431, 2008

- [75] F. R. Kschischang, B. J. Frey, and H.-A. Loeliger, "Factor graphs and the sum-product algorithm," *IEEE Trans. Inform. Theory*, vol. 47, no. 2, pp. 498–519, 2001.
- [76] Alireza Bayesteh, Eric Yi, Hosein Nikopour, and Hadi Baligh, "Blind Detection of SCMA for Uplink Grant-Free Multiple-Access", *IEEE ISWCS 2014*.
- [77] H., X. Dan and S. Shaowu. "On the Application of the Internet of Things in the Field of Medical and Health Care". *Green Computing and Communications (GreenCom), IEEE and Internet of Things (iThings/CPSCoM), IEEE International Conference on and IEEE Cyber, Physical and Social Computing*, 2013. Beijing.
- [78] Dai Xiaoming, S. Sun, and Y. Wang. "Reduced-Complexity (Quasi-Maximum-Likelihood Detectors with No Performance Degradation for S-QAM Modulated MIMO Systems". *Wireless Personal Commun*, vol. 66, no. 4, pp. 613-6273, Oct. 2009.
- [79] Ping, Li; Liu, Lihai; Leung, W.K.; "A Simple Approach to Near-Optimal Multi-user Detection: Interleave-Division Multiple-Access," in *Proc. IEEE Wireless Commun. Netw. Conf. (WCNC03)*, vol. 1, pp. 391396, Mar. 2003.
- [80] Kusume, K.; Bauch, G.; Utschick, W.; "IDMA vs. CDMA: Analysis and Comparison of Two Multiple Access Schemes," *IEEE Trans. Wireless Commun.*, Vol. 11, No. 1, pp. 7887, Jan. 2012.
- [81] Poveda, H.; Ferr, G.; Grivel, E.; "Frequency Synchronization and Channel Equalization for an OFDM-IDMA Uplink System," *2012 IEEE Int. Conf. Acoust. Speech Signal Process. (ICASSP12)*, pp. 32093212, Mar. 2012.
- [82] Vishvakshnan, K.S.; Seshasayanan, R.; Krishnamoorthy, Y.; "Joint VBLAST/STBC Assisted MIMO MC-IDMA System in Frequency Selective Channels: Performance Results," in *Proc. 2012 Int. Conf. Commun. Signal Process. (ICCSP12)*, Apr. 2012.
- [83] Chen, Y.; Schaich, F.; Wild, T.; "Multiple Access and Waveforms for 5G: IDMA and Universal Filtered Multi-Carrier," in *Proc. IEEE VTCs14*, Seoul, Korea, May 2014.
- [84] H. Jin, K. Peng, and J. Song, "Bit division multiplexing for broadcasting," *Broadcasting, IEEE Transactions on*, vol. 59, no. 3, pp. 539–547, Sept. 2013.
- [85] Jiachen Huang, Kewu Peng, Changyong Pan, Jian Song, Huangping Jin, and Zhisheng Niu "Bit Division Multiplexing for MIMO Broadcasting System" *IEEE 2014*.